



FB3000 Series

FB3000 Single Lane Flap Barrier Turnstile

FB3011 Single Lane Flap Barrier Turnstile
(w/ controller and RFID reader)

FB3022 Single Lane Flap Barrier Turnstile
(w/ controller and combination fingerprint & RFID reader)

The ZKAccess FB3000 single lane flap barrier turnstile is a compact and elegant cost-effective entrance control system designed for high-traffic volume.

The FB3000 is a single lane flap barrier turnstile series designed for smooth and silent operation and draws very little power. It's made of stainless steel which makes FB3000 highly durable. FB3000 is also surprisingly compact and designed to operate in small work places.

FB3000 tempered-glass barriers are normally held in a locked position, thus denying passage to the secured side. Upon FB3000's reader (RFID and/or fingerprint) positively recognizing a user's valid access card or fingerprint, its barriers retract upward automatically, thus allowing users passage to the secured side.

During emergencies and power outages the barriers automatically retract upward, thereby ensuring users FAST unencumbered exit to safety.

FB3000 provides both **security** and **convenience**, all in a very durable yet elegant compact design.

Built-in Reader Integration

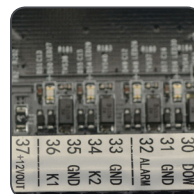

- FB3000 series ships already integrated with our customers' preference for either card or fingerprint access control reader. This greatly reduces installation time & expense.
- FB3000 series and associated access control readers are all factory-tested prior to shipping.
- ZKAccess provides true plug 'n play turnstiles with the lowest possible total cost of ownership in the industry!

Specifications

Power Supply	AC 220V/110V, 50/60Hz
Operating Temperature	-18F to 140F degrees
Operating Humidity	5%-85%
Working Environment	Indoor/Outdoor (if sheltered)
Rated Power	120W
Traffic Throughput	30 passages per minute
Casework Material and Barrier Material	SUS304 stainless steel and tempered glass
Visual Indicator	Yes. Access granted/denied and walking direction (entry or exit)
Audio Alarm	Yes
Control System	Input controlled by dry contact
Emergency Button Input	Yes
Infrared sensor	Triggers alarm upon detection of unauthorized users and tailgaters
Turnstile Dimension	39.4 (h) x 11.8 (w) x 47.2 (d) inches (100.4 x 30 x 120 centimeters + arm length 50 centimeters)
Wooden Crate Dimension	55.1 x 43.3 x 15.7 inches
Turnstile Weight	297.6 lbs. (135 kg)
Turnstile and Wooden Crate Combined Weight	452 lbs. (205 kg)

Dimensions (inches)

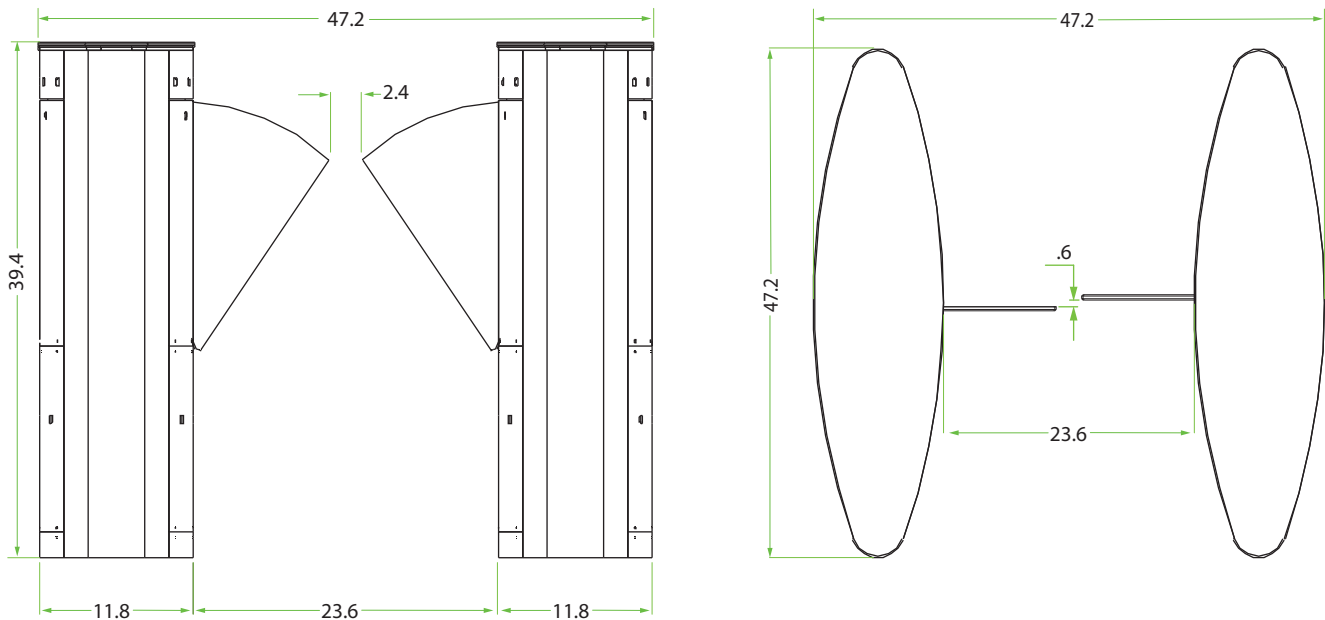

ZKAccess

6 Kingsbridge Road, Unit 8, Fairfield, NJ 07004
 Phone: (862) 505-2101 • Fax: (862) 204-5906 • sales@zkaccess.com • www.zkaccess.com

© Copyright 2016. ZKTeco Inc. ZKTeco Logo and ZKAccess Logo are registered trademarks of ZKTeco or a related company. All other product and company names mentioned are used for identification purposes only and may be the trademarks of their respective owners. All specifications are subject to change without notice. All rights reserved.

